

## On the changes in phase speed of one train of water waves in the presence of another

By S. J. HOGAN,† IDITH GRUMAN‡ AND M. STIASSNIE‡

†Mathematical Institute, University of Oxford, St Giles, Oxford, OX1 3LB, UK.

‡Department of Civil Engineering, Technion, Haifa 32000, Israel

(Received 7 August 1987)

We present calculations of the change in phase speed of one train of water waves in the presence of another. We use a general method, based on Zakharov's (1968) integral equation. It is shown that the change in phase speed of each wavetrain is directly proportional to the square of the amplitude of the other. This generalizes the work of Longuet-Higgins & Phillips (1962) who considered gravity waves only.

In the important case of gravity-capillary waves, we present the correct form of the Zakharov kernel. This is used to find the expressions for the changes in phase speed. These results are then checked using a perturbation method based on that of Longuet-Higgins & Phillips (1962). Agreement to 6 significant digits has been obtained between the calculations based on these two distinct methods. Full numerical results in the form of polar diagrams over a wide range of wavelengths, away from conditions of triad resonance, are provided.

---

### 1. Introduction

Longuet-Higgins & Phillips (1962) showed that the phase speed of one wavetrain on the surface of an ideal fluid is modified in the presence of another, and vice versa. This change is different from, but the same order as, that change predicted by Stokes (1847) due to the finite amplitude of the wave itself.

These changes in phase speed can be traced to the fact that surface gravity waves interact in sets of four waves if the resonance conditions

$$\sigma_1 \pm \sigma_2 \pm \sigma_3 \pm \sigma_4 = 0, \quad (1.1)$$

$$\mathbf{k}_1 \pm \mathbf{k}_2 \pm \mathbf{k}_3 \pm \mathbf{k}_4 = 0 \quad (1.2)$$

are met. Here  $\sigma$  is the linearized wave frequency and  $\mathbf{k}$  the wavenumber, related by the dispersion relation

$$\sigma_i^2 = g|\mathbf{k}_i| \quad (i = 1, 2, 3, 4), \quad (1.3)$$

where  $g$  is the acceleration due to gravity. Most of the interactions lead to energy transfer as is now well known (Phillips 1977, §3.8) but a subset of interactions leads only to a phase change. Thus when all the wavenumbers are equal and all the wave frequencies are equal we obtain the Stokes correction. In addition, when the wavenumbers are equal in pairs (and hence the corresponding wave frequencies are also equal in pairs) we obtain the Longuet-Higgins & Phillips (1962) correction.

The present study generalizes this earlier work in a number of important ways. In §2, we give a general method to find the change in phase speed. This is based on Zakharov's (1968) equation and shows that we only need the Zakharov kernel  $T(\mathbf{k}, \mathbf{k}_1, \mathbf{k}_2, \mathbf{k}_3)$  in order to obtain this change. In fact if  $\Delta c_2$  is the change in phase

speed of wavetrain 2 due to the presence of wavetrain 1, then we find that  $\Delta c_2$  is independent of  $a_2$  and directly proportional to  $a_1^2$ , where  $a_i$  is the amplitude of wavetrain  $i$ . This generalizes the result of Longuet-Higgins & Phillips (1962).

In §3, we compare our results in the case of gravity-only propagation with those of Longuet-Higgins & Phillips (1962). We find full agreement with their work, provided a small printing error is corrected.

The important case of gravity-capillary waves is then considered. We find that the kernel  $T(\mathbf{k}, \mathbf{k}_1, \mathbf{k}_2, \mathbf{k}_3)$  given by Zakharov (1968) is incorrect. We give the correct form in §4.

In §5 we give an alternative derivation of  $\Delta c_2$  in the case of gravity-capillary waves, based on the perturbation analysis of Longuet-Higgins & Phillips (1962), although our method is slightly different. The two separate expressions for  $\Delta c_2$  are found to yield identical numerical values.

We give some simple expressions for  $\Delta c_2$  in §6 for the case of collinear propagation. We consider separately the cases of gravity-only motion, surface tension only and motion under the combined effects of gravity and surface tension. We draw attention to the areas of triad resonance in which our results are not applicable.

In §7, we give full numerical results in the form of polar diagrams over a wide range of wavelengths, for arbitrary angle of intersection of the wavetrains, and discuss their significance. Regions of possible triad interaction are indicated.

Section 8 is devoted to a summary of our results. We provide the full corrected version of Zakharov's kernel function  $T(\mathbf{k}, \mathbf{k}_1, \mathbf{k}_2, \mathbf{k}_3)$  for gravity-capillary waves in the Appendix.

## 2. General method

In this section, we give a general method for calculating the change in phase speed of one train of water waves in the presence of another, using Zakharov's (1968) integral equation. This is given by

$$i \frac{\partial B}{\partial t}(\mathbf{k}, t) = \iiint_{-\infty}^{\infty} T(\mathbf{k}, \mathbf{k}_1, \mathbf{k}_2, \mathbf{k}_3) B^*(\mathbf{k}_1, t) B(\mathbf{k}_2, t) B(\mathbf{k}_3, t) \\ \times \delta(\mathbf{k} + \mathbf{k}_1 - \mathbf{k}_2 - \mathbf{k}_3) \times \exp\{i[\sigma(\mathbf{k}) + \sigma(\mathbf{k}_1) - \sigma(\mathbf{k}_2) - \sigma(\mathbf{k}_3)]\} d\mathbf{k}_1 d\mathbf{k}_2 d\mathbf{k}_3, \quad (2.1)$$

where  $B(\mathbf{k}, t)$  is related to the free surface  $\zeta(\mathbf{x}, t)$  by

$$\zeta(\mathbf{x}, t) = \frac{1}{2\pi} \int_{-\infty}^{\infty} \left( \frac{|\mathbf{k}|}{2\sigma(\mathbf{k})} \right)^{\frac{1}{2}} \{B(\mathbf{k}, t) \exp\{i(\mathbf{k} \cdot \mathbf{x} - \sigma(\mathbf{k}) t)\} + *\} d\mathbf{k}. \quad (2.2)$$

The complex conjugate is denoted by  $*$ ,  $\mathbf{k}$  is the wave vector  $\mathbf{x}$  is the horizontal spatial vector and  $t$  is time. The linearized wave frequency  $\sigma$  is related to  $\mathbf{k}$  through the linear dispersion relation of the waves of interest. The kernel  $T(\mathbf{k}, \mathbf{k}_1, \mathbf{k}_2, \mathbf{k}_3)$  is a real function of its variables, and is taken in the form symmetric in  $\mathbf{k}_2, \mathbf{k}_3$  that is uniquely defined (see §3 in Stiassnie & Shemer 1984). For strict resonance conditions, given by (1.1), (1.2),  $T$  is also symmetric in its first two arguments  $\mathbf{k}, \mathbf{k}_1$ .

Equation (2.1) describes the evolution of a weakly nonlinear wave field on a timescale given by  $\epsilon^{-2}P$ , where  $\epsilon$  is a small parameter describing the nonlinearity and  $P$  is a typical wave period. Inherent in the derivation is the assumption that the frequency difference  $\Delta\sigma = \sigma(\mathbf{k}) + \sigma(\mathbf{k}_1) - \sigma(\mathbf{k}_2) - \sigma(\mathbf{k}_3)$  is of order  $\epsilon^2$ , but there is no necessity for the spectrum to be narrowbanded.

We now consider the consequence of taking two weakly nonlinear wavetrains,

denoted by 1 and 2, to make up the free surface and look for simple phase-change solutions that might result. Thus we take

$$B(\mathbf{k}, t) = B_1(t) \delta(\mathbf{k} - \mathbf{k}_1) + B_2(t) \delta(\mathbf{k} - \mathbf{k}_2) \quad (2.3)$$

and substitute (2.3) into (2.1) to find

$$i \frac{dB_1}{dt} = T(\mathbf{k}_1, \mathbf{k}_1, \mathbf{k}_1, \mathbf{k}_1) |B_1|^2 B_1 + \{T(\mathbf{k}_1, \mathbf{k}_2, \mathbf{k}_1, \mathbf{k}_2) + T(\mathbf{k}_1, \mathbf{k}_2, \mathbf{k}_2, \mathbf{k}_1)\} |B_2|^2 B_1 \quad (2.4)$$

and

$$i \frac{dB_2}{dt} = T(\mathbf{k}_2, \mathbf{k}_2, \mathbf{k}_2, \mathbf{k}_2) |B_2|^2 B_2 + \{T(\mathbf{k}_2, \mathbf{k}_1, \mathbf{k}_2, \mathbf{k}_1) + T(\mathbf{k}_2, \mathbf{k}_1, \mathbf{k}_1, \mathbf{k}_2)\} |B_1|^2 B_2. \quad (2.5)$$

In what follows we denote  $T(\mathbf{k}_1, \mathbf{k}_1, \mathbf{k}_1, \mathbf{k}_1)$  by  $T_1$  and  $T(\mathbf{k}_2, \mathbf{k}_2, \mathbf{k}_2, \mathbf{k}_2)$  by  $T_2$ . The above-mentioned symmetry properties of  $T(\mathbf{k}, \mathbf{k}_1, \mathbf{k}_2, \mathbf{k}_3)$  allow us to write both of the expressions in the curly brackets of (2.4) and (2.5) as  $2T(\mathbf{k}_1, \mathbf{k}_2, \mathbf{k}_1, \mathbf{k}_2)$ , which we will denote by  $2T_{1,2}$ . We also denote  $|\mathbf{k}_i|$  as  $k_i$  and  $\sigma(\mathbf{k}_i)$  as  $\sigma_i$ .

The solution of the pair of ordinary differential equations (2.4) and (2.5) is given by

$$B_1(t) = A_1 \exp\{-i(T_1 A_1^2 + 2T_{1,2} A_2^2)t\}, \quad (2.6)$$

$$B_2(t) = A_2 \exp\{-i(T_2 A_2^2 + 2T_{1,2} A_1^2)t\}, \quad (2.7)$$

We now substitute (2.3), (2.6) and (2.7) into (2.2). We can write the result in the form

$$\zeta(\mathbf{x}, t) = a_1 \cos(\mathbf{k}_1 \cdot \mathbf{x} - \Omega_1 t) + a_2 \cos(\mathbf{k}_2 \cdot \mathbf{x} - \Omega_2 t), \quad (2.8)$$

where the quantities  $a_1$  and  $a_2$  represent the amplitudes of the two wave-trains. They also define the constants  $A_1$  and  $A_2$  as

$$A_i = 2\pi \left( \frac{\sigma_i}{2k_i} \right)^{\frac{1}{2}} a_i \quad (i = 1, 2). \quad (2.9)$$

The frequencies of the wavetrains are given by

$$\Omega_1 = \sigma_1 + T_1 A_1^2 + 2T_{1,2} A_2^2 \quad (2.10)$$

and

$$\Omega_2 = \sigma_2 + T_2 A_2^2 + 2T_{1,2} A_1^2. \quad (2.11)$$

The change in the frequency of each wavetrain is therefore made up of two parts. In (2.11) for example, the first correction to  $\sigma_2$  is given by  $T_2 A_2^2$  which is the well-known Stokes (1847) correction. This term is due to the nonlinearity of the wavetrain itself and is present even if the other wavetrain is absent. The second correction is given by  $2T_{1,2} A_1^2$  and is entirely due to the presence of the other wave-train. It is the same order as the usual Stokes correction.

The phase speed of this wavetrain can be given by

$$c_2 = \Omega_2 / k_2 \quad (2.12)$$

and so the change in phase speed of the weakly nonlinear wavetrain 2 due to the presence of wavetrain 1,  $\Delta c_2$ , is given by

$$\Delta c_2 = c_2 - \frac{(\sigma_2 + T_2 A_2^2)}{k_2} \quad (2.13)$$

$$= \frac{2T_{1,2} A_1^2}{k_2}. \quad (2.14)$$

Using (2.9), this becomes

$$\Delta c_2 = \frac{4\pi^2 \sigma_1}{k_1 k_2} T_{1,2} a_1^2. \quad (2.15)$$

Thus we only need  $T_{1,2}$  to evaluate  $\Delta c_2$  and we have shown that this change in phase velocity is independent of the amplitude of wavetrain 2. This latter result was obtained for gravity waves only by Longuet-Higgins & Phillips (1962). We see now that it is true in general.

In a similar way one can show that the change in phase speed of the weakly nonlinear wavetrain 1 due to the presence of wavetrain 2 is

$$\Delta c_1 = \frac{4\pi^2 \sigma_2}{k_1 k_2} T_{1,2} a_2^2. \quad (2.16)$$

### 3. Gravity waves

In the case of gravity waves propagating on the surface of an ideal fluid of infinite depth, the linearized dispersion relation is given by (1.3). The Zakharov kernel function  $T(\mathbf{k}, \mathbf{k}_1, \mathbf{k}_2, \mathbf{k}_3)$  was originally given in Zakharov (1968) but it is more readily available in compact form in Crawford *et al.* (1981).

As we have noted before, the quantity  $\Delta c_2$  has been calculated previously in this case by Longuet-Higgins & Phillips (1962), who obtained the expression

$$\Delta c_2 = K' / 2a_2 \sigma_2^2, \quad (3.1)$$

where  $K'$  is given in their equation (2.8).

There is a misprint in their expression for  $K'$ . This has been noted by Willebrand (1975) and given explicitly by Cleaver (1980). In fact

$$\begin{aligned} K' = a_1^2 a_2 \sigma_1 \sigma_2 \left[ (\sigma_1 - \sigma_2) |\mathbf{k}_1 - \mathbf{k}_2| \cos^2 \frac{1}{2} \theta \left\{ 1 + \frac{4\sigma_1 \sigma_2 \sin^2 \frac{1}{2} \alpha}{(\sigma_1 - \sigma_2)^2 - g|\mathbf{k}_1 - \mathbf{k}_2|} \right\} \right. \\ \left. + (\sigma_1 + \sigma_2) |\mathbf{k}_1 + \mathbf{k}_2| \sin^2 \frac{1}{2} \theta \left\{ 1 - \frac{4\sigma_1 \sigma_2 \sin^2 \frac{1}{2} \beta}{(\sigma_1 + \sigma_2)^2 - g|\mathbf{k}_1 + \mathbf{k}_2|} \right\} \right. \\ \left. + \sigma_1 (k_1 - k_2 + 2k_2 \cos^2 \frac{1}{2} \theta \sin^2 \frac{1}{2} \theta) + \sigma_2 (k_1 + k_2) \cos \theta \right], \quad (3.2) \end{aligned}$$

where the angles  $\alpha$ ,  $\beta$  and  $\theta$  are defined in figure 1. This can be traced to equation (3.15) of Longuet-Higgins (1962) which should read

$$\begin{aligned} \mathbf{u}_{10} \cdot \nabla (\mathbf{u}_{10} \cdot \mathbf{u}_{01}) = a_1^2 a_2 \sigma_1^2 \sigma_2 [(k_1 + 2k_2 \cos^2 \frac{1}{2} \theta \sin^2 \frac{1}{2} \theta) \sin \psi_2 \\ + k_2 \cos^4 \frac{1}{2} \theta \sin (2\psi_1 - \psi_2) - k_2 \sin^4 \frac{1}{2} \theta \sin (2\psi_1 + \psi_2)]. \quad (3.3) \end{aligned}$$

In turn this modifies equation (2.5) of Longuet-Higgins & Phillips (1962) in the obvious manner which then leads to our (3.2) above.

We have obtained numerical agreement between (2.15) and (3.1) for arbitrary values of  $\theta$ , when (3.2) is used to define the quantity  $K'$ .

### 4. The function $T(\mathbf{k}, \mathbf{k}_1, \mathbf{k}_2, \mathbf{k}_3)$ for gravity-capillary waves

The linearized dispersion relation in this case is given by

$$\sigma^2 = gk + Sk^3, \quad (4.1)$$

where  $S$  is the surface tension coefficient divided by the density of the fluid. The kernel  $T(\mathbf{k}_0, \mathbf{k}_1, \mathbf{k}_2, \mathbf{k}_3)$  was given originally by Zakharov (1968) in this general case,

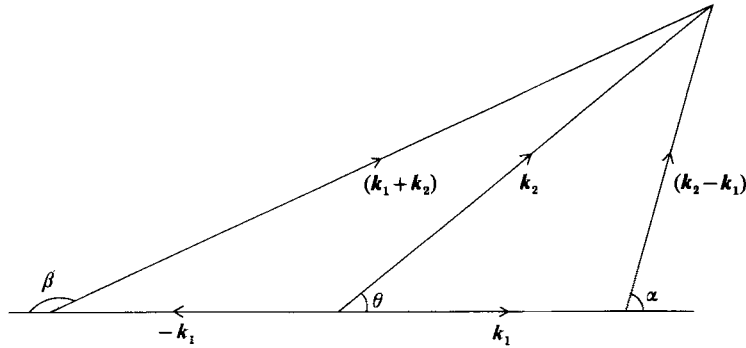
FIGURE 1. Definition sketch for the angles  $\alpha$ ,  $\beta$  and  $\theta$ .

which differs from that of the previous section by a term proportional to  $S$ . This term in Zakharov's paper is incorrect. In fact we can now show that the third-order interaction coefficient  $W_{0,1,2,3}$  (using the notation of Crawford *et al.* (1981)) should be modified to become

$$W'_{0,1,2,3} = W_{0,1,2,3} - \frac{S}{32\pi^2} \frac{(k_0 k_1 k_2 k_3)^{\frac{1}{2}}}{(\sigma_0 \sigma_1 \sigma_2 \sigma_3)^{\frac{1}{2}}} [(\mathbf{k}_0 \cdot \mathbf{k}_1)(\mathbf{k}_2 \cdot \mathbf{k}_3) + (\mathbf{k}_0 \cdot \mathbf{k}_2)(\mathbf{k}_1 \cdot \mathbf{k}_3) + (\mathbf{k}_0 \cdot \mathbf{k}_3)(\mathbf{k}_1 \cdot \mathbf{k}_2)]. \quad (4.2)$$

We give the full form of the function  $T(\mathbf{k}, \mathbf{k}_1, \mathbf{k}_2, \mathbf{k}_3)$  for gravity-capillary waves in the Appendix. We obtained (4.2) following the procedure given in §VIA of Yuen & Lake (1982). The work of Hogan (1985, 1986) is unaffected by this change because the two forms of the additional term are identical to the order of expansion used in those papers.

## 5. Perturbation method

The results of the previous section provide us with the correct form of the kernel  $T$  to be used in (2.15) for the quantity  $\Delta c_2$  in the case of gravity-capillary waves. There is no published alternative derivation of this quantity. Holliday (1977) gives a recipe but does not give any results, either analytic or numerical. In this section therefore we present an independent method for deriving  $\Delta c_2$  based on the work of Longuet-Higgins & Phillips (1962).

The derivation and notation herein follow closely those of Longuet-Higgins (1962) and Longuet-Higgins & Phillips (1962). Thus we have an ideal fluid of infinite depth whose fluid velocity is given by  $\mathbf{u} = \nabla\varphi$ . The motion is incompressible and so the velocity potential  $\varphi$  satisfies

$$\nabla^2\varphi = 0. \quad (5.1)$$

In rectangular Cartesian coordinates  $(x, y, z)$ ,  $z$  is the vertical coordinate. We must satisfy the kinematic condition

$$\frac{\partial\zeta}{\partial t} - \frac{\partial\varphi}{\partial z} + \left( \frac{\partial\varphi}{\partial x} \frac{\partial\zeta}{\partial x} + \frac{\partial\varphi}{\partial y} \frac{\partial\zeta}{\partial y} \right) = 0 \quad \text{on } z = \zeta \quad (5.2)$$

and Bernoulli's equation

$$\frac{\partial\varphi}{\partial t} + \frac{1}{2}u^2 + g\zeta - \frac{S}{R} = 0 \quad \text{on } z = \zeta, \quad (5.3)$$

where  $R$  is the radius of curvature of the surface.

Both (5.2) and (5.3) can be expanded in a Taylor series about  $z = 0$  to give

$$g\zeta + \left[ \frac{\partial\varphi}{\partial t} + \zeta \frac{\partial^2\varphi}{\partial z \partial t} + \frac{1}{2}\zeta^2 \frac{\partial^3\varphi}{\partial z^2 \partial t} + \dots \right] + \left[ \frac{1}{2}u^2 + \zeta \frac{\partial}{\partial z} \left( \frac{1}{2}u^2 \right) + \dots \right] \\ - S \left\{ \frac{\partial^2\zeta}{\partial x^2} + \frac{\partial^2\zeta}{\partial y^2} - \frac{1}{2} \frac{\partial^2\zeta}{\partial x^2} \left[ 3 \left( \frac{\partial\zeta}{\partial x} \right)^2 + \left( \frac{\partial\zeta}{\partial y} \right)^2 \right] - \frac{1}{2} \frac{\partial^2\zeta}{\partial y^2} \left[ \left( \frac{\partial\zeta}{\partial x} \right)^2 + 3 \left( \frac{\partial\zeta}{\partial y} \right)^2 \right] \right. \\ \left. - 2 \frac{\partial\zeta}{\partial x} \frac{\partial\zeta}{\partial y} \frac{\partial^2\zeta}{\partial x \partial y} + \dots \right\} = 0 \quad \text{on } z = 0 \quad (5.4)$$

and

$$\frac{\partial\zeta}{\partial t} - \left[ \frac{\partial\varphi}{\partial z} + \zeta \frac{\partial^2\varphi}{\partial z^2} + \frac{1}{2}\zeta^2 \frac{\partial^3\varphi}{\partial z^3} + \dots \right] \\ + \left[ \left( \frac{\partial\varphi}{\partial x} \frac{\partial\zeta}{\partial x} + \frac{\partial\varphi}{\partial y} \frac{\partial\zeta}{\partial y} \right) + \zeta \left( \frac{\partial^2\varphi}{\partial z \partial x} \frac{\partial\zeta}{\partial x} + \frac{\partial^2\varphi}{\partial z \partial y} \frac{\partial\zeta}{\partial y} \right) + \dots \right] = 0 \quad \text{on } z = 0. \quad (5.5)$$

We now substitute expansions for  $\varphi$ ,  $\mathbf{u}$  and  $\zeta$  into (5.4) and (5.5) which represent the two wavetrains and their nonlinear interactions. We take

$$\varphi = \alpha\varphi_{10} + \beta\varphi_{01} + \alpha^2\varphi_{20} + \alpha\beta\varphi_{11} + \beta^2\varphi_{02} + \dots, \quad (5.6)$$

$$\mathbf{u} = \alpha\mathbf{u}_{10} + \beta\mathbf{u}_{01} + \alpha^2\mathbf{u}_{20} + \alpha\beta\mathbf{u}_{11} + \beta^2\mathbf{u}_{02} + \dots, \quad (5.7)$$

$$\zeta = \alpha\zeta_{10} + \beta\zeta_{01} + \alpha^2\zeta_{20} + \alpha\beta\zeta_{11} + \beta^2\zeta_{02} + \dots, \quad (5.8)$$

where the independent variables  $\alpha$  and  $\beta$  are proportional to the wave slopes.

The terms to  $O(\alpha)$  are satisfied by

$$\zeta_{10} = a_1 \cos \psi_1: \quad \varphi_{10} = \frac{a_1 \sigma_1}{k_1} e^{k_1 z} \sin \psi_1, \quad (5.9)$$

where

$$\psi_i = \mathbf{k}_i \cdot \mathbf{x} - \sigma_i t \quad (i = 1, 2). \quad (5.10)$$

We eventually want to consider terms at  $O(\alpha^2\beta)$ . In order to do this we must first consider  $O(\alpha^2)$  and  $O(\alpha\beta)$ . Thus to  $O(\alpha^2)$ , the equations can be solved by taking

$$\zeta_{20} = \frac{\sigma_1^2 a_1^2}{2(g - 2Sk_1^2)} \cos 2\psi_1: \quad \varphi_{20} = \frac{3a_1^2 \sigma_1 k_1^2 S e^{2k_1 z}}{2(g - 2Sk_1^2)} \sin 2\psi_1. \quad (5.11)$$

In this way we recover the well-known results that  $\varphi_{20} = 0$  when  $S = 0$  and  $\varphi_{20}$ ,  $\zeta_{20}$  are both singular when  $k_1^2 = g/2S$  (Wehausen & Laitone 1960, equations (27.12), (27.13)).

To  $O(\alpha\beta)$  the equations are solved by taking

$$\zeta_{11} = C \cos(\psi_1 - \psi_2) - D \cos(\psi_1 + \psi_2), \quad (5.12)$$

where

$$\varphi_{11} = A e^{|\mathbf{k}_1 - \mathbf{k}_2|z} \sin(\psi_1 - \psi_2) - B e^{|\mathbf{k}_1 + \mathbf{k}_2|z} \sin(\psi_1 + \psi_2), \quad (5.13)$$

$$A = \frac{a_1 a_2}{2[(\sigma_1 - \sigma_2)^2 - (g + S|\mathbf{k}_1 - \mathbf{k}_2|^2)|\mathbf{k}_1 - \mathbf{k}_2|]} \{ [\sigma_1 k_1 - \sigma_2 k_2 + (\sigma_2 k_1 - \sigma_1 k_2) \cos \theta] \\ \times (g + S|\mathbf{k}_1 - \mathbf{k}_2|^2) - (\sigma_1 - \sigma_2) [\sigma_1^2 + \sigma_2^2 - 2\sigma_1 \sigma_2 \cos^2 \frac{1}{2}\theta] \}, \quad (5.14)$$

$$B = \frac{a_1 a_2}{2[(\sigma_1 + \sigma_2)^2 - (g + S|\mathbf{k}_1 + \mathbf{k}_2|^2)|\mathbf{k}_1 + \mathbf{k}_2|]} \{ -[\sigma_1 k_1 + \sigma_2 k_2 + (\sigma_1 k_2 + \sigma_2 k_1) \cos \theta] \\ \times (g + S|\mathbf{k}_1 + \mathbf{k}_2|^2) + (\sigma_1 + \sigma_2) [\sigma_1^2 + \sigma_2^2 + 2\sigma_1 \sigma_2 \sin^2 \frac{1}{2}\theta] \}, \quad (5.15)$$

$$C = \frac{a_1 a_2}{2[(\sigma_1 - \sigma_2)^2 - (g + S|\mathbf{k}_1 - \mathbf{k}_2|^2)|\mathbf{k}_1 - \mathbf{k}_2]} \{[\sigma_1 k_1 - \sigma_2 k_2 + (\sigma_2 k_1 - \sigma_1 k_2) \cos \theta] \\ \times (\sigma_1 - \sigma_2) - |\mathbf{k}_1 - \mathbf{k}_2| [\sigma_1^2 + \sigma_2^2 - 2\sigma_1 \sigma_2 \cos^2 \frac{1}{2}\theta]\}, \quad (5.16)$$

$$D = \frac{a_1 a_2}{2[(\sigma_1 + \sigma_2)^2 - (g + S|\mathbf{k}_1 + \mathbf{k}_2|^2)|\mathbf{k}_1 + \mathbf{k}_2]} \{-[\sigma_1 k_1 + \sigma_2 k_2 + (\sigma_1 k_2 + \sigma_2 k_1) \cos \theta] \\ \times (\sigma_1 + \sigma_2) + |\mathbf{k}_1 + \mathbf{k}_2| [\sigma_1^2 + \sigma_2^2 + 2\sigma_1 \sigma_2 \sin^2 \frac{1}{2}\theta]\}. \quad (5.17)$$

We are now at the final stage of the expansions. We seek expressions for  $\zeta_{21}$  and  $\varphi_{21}$ . These terms occur at  $O(\alpha^2\beta)$  and they account for the interaction of the two wavetrains at this order. But we only seek the terms involving  $\cos \psi_2$  in (5.4) and  $\sin \psi_2$  in (5.5). This is because only these terms contribute to the wave-field components with wavenumber equal to  $\mathbf{k}_2$ , which in turn give rise to the phase shifts in  $\zeta$ . There will be other terms such as  $\sin(2\psi_1 - \psi_2)$  but these have different wavenumbers and so will not produce pure phase shifts. These terms were considered in Longuet-Higgins (1962). Thus we shall ignore these terms in what follows and find

$$g\zeta_{21} + \frac{\partial \varphi_{21}}{\partial t} - S \left( \frac{\partial^2}{\partial x^2} + \frac{\partial^2}{\partial y^2} \right) \zeta_{21} + L \cos \psi_2 = 0 \quad (5.18)$$

and

$$\frac{\partial \zeta_{21}}{\partial t} - \frac{\partial \varphi_{21}}{\partial x} + M \sin \psi_2 = 0, \quad (5.19)$$

where  $L$  and  $M$  are lengthy expressions involving  $a_1$ ,  $a_2$ ,  $k_1$ ,  $k_2$ ,  $\sigma_1$ ,  $\sigma_2$  and the constants  $A$ ,  $B$ ,  $C$  and  $D$ .

Let us now take

$$\zeta_{21} = \delta t \sin \psi_2, \quad \varphi_{21} = \gamma t e^{k_2 z} \cos \psi_2 \quad (5.20)$$

and substitute these into (5.18) and (5.19). We find

$$\delta = \frac{1}{2\sigma_2} (Lk_2 - M\sigma_2), \quad \gamma = \frac{1}{2k_2} (M\sigma_2 - Lk_2) \quad (5.21)$$

and hence

$$\zeta = \zeta_{01} + \zeta_{03} + \zeta_{21} \\ = a_2 \cos \left[ \mathbf{k}_2 \cdot \mathbf{x} - \left[ 1 + \frac{\delta}{a_2 \sigma_2} + \gamma (a_2 k_2)^2 \right] \sigma_2 t \right] \quad (5.22)$$

provided

$$\left[ \gamma (a_2 k_2)^2 + \frac{\delta}{a_2 \sigma_2} \right] \sigma_2 t \ll 1. \quad (5.23)$$

The quantity  $\gamma$  is the well-known Stokes correction to the phase velocity of a wave due to its own cubic self-interaction (nonlinearity). In this case, it is possible to show that

$$T_2 = \frac{k_2^3}{2\pi^2} \gamma, \quad (5.24)$$

which verifies the second term on the right-hand side of (2.11). Thus the change in the phase velocity of wave 2 in the presence of wave 1 is given by

$$\Delta c_2 = \frac{\sigma_2}{k_2} \frac{\delta}{a_2 \sigma_2} = \frac{\delta}{a_2 k_2}, \quad (5.25)$$

---

$K$	$k_1$	$k_2$	$T_{1,2}$	$k_1 \delta / 4\pi^2 \sigma_1$
0	(1, 0)	(2, 0)	0.050661	0.050661
10	(1, 0)	(2, 0)	-0.009710	-0.009710
$\infty$	(1, 0)	(2, 0)	-0.010650	-0.010650
0	(1, 0)	(1, 1)	0.024998	0.024998
10	(1, 0)	(1, 1)	-0.003086	-0.003086
$\infty$	(1, 0)	(1, 1)	-0.002520	-0.002520

---

TABLE 1. Numerical confirmation of equality of  $T_{1,2}$  and  $k_1 \delta / 4\pi^2 \sigma_1$ 

where the coefficient  $\delta$  is given by the expression

$$\begin{aligned} \delta = & \frac{a_1}{4\sigma_2} \{A|\mathbf{k}_1 - \mathbf{k}_2| [\sigma_2 k_2 - \sigma_2 |\mathbf{k}_1 - \mathbf{k}_2| - \cos \alpha (\sigma_2 k_1 + \sigma_1 k_2)] \\ & + B|\mathbf{k}_1 + \mathbf{k}_2| [\sigma_2 k_2 - \sigma_2 |\mathbf{k}_1 + \mathbf{k}_2| - \cos \beta (\sigma_2 k_1 - \sigma_1 k_2)] \\ & + \sigma_1 k_2 (\sigma_2 \cos \theta - \sigma_1) (C - D) \\ & + a_1 a_2 k_2 [\sigma_1^2 k_1 + \sigma_1 \sigma_2 (2k_1 + k_2) \cos \theta - \frac{1}{2} S k_1^2 k_2^2 (\sin^2 \theta + 3 \cos^2 \theta)] \}, \end{aligned} \quad (5.26)$$

where  $A$ ,  $B$ ,  $C$  and  $D$  are given in (5.14)–(5.17).

Note that we have to retain throughout the separate identities of the two boundary conditions, (5.4) and (5.5), instead of combining them as done by Longuet-Higgins & Phillips (1962).

We should emphasize that each expression obtained here has been shown analytically to reduce to the corresponding one for  $S = 0$  given by Longuet-Higgins (1962) or Longuet-Higgins & Phillips (1962) for arbitrary angle  $\theta$ , when due account is taken of the misprint as outlined in our §3.

We have also shown numerically that (5.25) and (5.26) does equal equation (2.15) when the modification suggested in (4.2) is applied. Thus our two separate expressions for  $\Delta c_2$  are shown to be equal. We give some examples in table 1, where  $\delta = a_1^2 a_2 \delta$  and  $K = S k_1^2 / g$ .

## 6. Collinear wavetrains

We now evaluate the change in phase velocity in four special cases. Thus we consider  $\mathbf{k}_1$  parallel and antiparallel to  $\mathbf{k}_2$  with  $k_1 > k_2$  and  $k_1 < k_2$ . We consider flow under gravity only, under surface tension only and under the combined effects of gravity and surface tension.

### 6.1. Gravity only

We set  $S = 0$  in (5.25). For  $\mathbf{k}_1$  parallel to  $\mathbf{k}_2$  and  $k_1 < k_2$  (case (i)) we set  $\theta = \alpha = 0$  and  $\beta = \pi$  in figure 1 and find

$$\Delta c_2 = a_1^2 k_1 \sigma_1. \quad (6.1)$$

If  $k_1 > k_2$ , (case (ii)), then  $\theta = 0$ ,  $\alpha = \beta = \pi$  and we find

$$\Delta c_2 = a_1^2 k_2 \sigma_1. \quad (6.2)$$

For  $\mathbf{k}_1$  parallel to  $-\mathbf{k}_2$  and  $k_1 < k_2$  (case (iii)) we take  $\theta = \alpha = \pi$  and  $\beta = 0$  to find

$$\Delta c_2 = -a_1^2 k_1 \sigma_1, \quad (6.3)$$



and if  $k_1 > k_2$  (case (iv)) we take  $\theta = \alpha = \beta = \pi$  and find

$$\Delta c_2 = -a_1^2 k_2 \sigma_1. \quad (6.4)$$

In this way we recover the results in §3 of Longuet-Higgins & Phillips (1962).

### 6.2. Surface tension only

Here we set  $g = 0$  and take  $\sigma_i^2 = Sk_i^3$  ( $i = 1, 2$ ). In all cases it turns out that we can express the results in terms of the quantity  $\eta$  where  $\eta^2 = k_1/k_2$ . This property of pure capillary-wave interactions has been noted before by McGoldrick (1965).

Thus for case (i) we find

$$\Delta c_2 = \frac{1}{8}(a_1 k_1)^2 \frac{\sigma_2}{k_2} H(\eta), \quad (6.5)$$

where

$$H(\eta) = \frac{-27 + 72\eta - 78\eta^2 + 32\eta^3 + 27\eta^4 - 24\eta^5 - 32\eta^6 + 48\eta^7 - 18\eta^8}{(9 - 12\eta + 4\eta^2 - 3\eta^4 - 4\eta^5 + 6\eta^6)}. \quad (6.6)$$

For case (ii), we obtain

$$\Delta c_2 = \frac{1}{8}(a_1 k_1)^2 \frac{\sigma_2}{k_2} H\left(\frac{1}{\eta}\right). \quad (6.7)$$

For the two antiparallel cases, the results are similar (but not the negative of (6.5) and (6.7)). In case (iii), we find

$$\Delta c_2 = \frac{1}{8}(a_1 k_1)^2 \frac{\sigma_2}{k_2} H(-\eta), \quad (6.8)$$

and for case (iv),

$$\Delta c_2 = \frac{1}{8}(a_1 k_1)^2 \frac{\sigma_2}{k_2} H\left(\frac{-1}{\eta}\right). \quad (6.9)$$

It is clear that we need only consider the value of  $H(\eta)$  for  $-1 \leq \eta \leq 1$  in order to cover all four cases above. This is done in figure 2 where we plot  $H(\eta)$  in the range  $-1 \leq \eta \leq 1$ . Note that  $H(\eta)$  is always negative and monotonically increases from  $H = -8$  at  $\eta = -1$  to  $H = -1$  at  $\eta = +1$ .

Thus we find that whereas for gravity – only motion parallel propagation leads to an increase and antiparallel propagation to a decrease in phase speed, the quantity  $\Delta c_2$  is always negative for surface-tension-only motion. Nevertheless this is quite in keeping with the fact that the cubic self-interaction term  $\gamma = \frac{1}{2}$  when  $S = 0$  but changes sign to  $\gamma = -\frac{1}{16}$  when  $g = 0$ .

We note that the complicated expression for  $H(\eta)$  was originally obtained directly from the gravity-free equations of motion and subsequently as a limit of the general equation (5.25), as well as from (2.15) to give an excellent check on its validity. Also it has been successfully used to verify computer calculations of the normal mode perturbations to fully nonlinear pure capillary waves (Hogan 1988).

### 6.3. Gravity and surface tension

The various expressions for  $\Delta c_2$  in the combined case of gravity and surface-tension propagation are now derived for the four special cases. Let us take

$$R_j = \frac{g}{Sk_j^2} \quad (j = 1, 2), \quad r = \frac{Sk_1 k_2}{4\sigma_1 \sigma_2}, \quad (6.10)$$

where now  $\sigma_j^2 = gk_j + Sk_j^3 = Sk_j^3(1 + R_j)$  ( $j = 1, 2$ ).

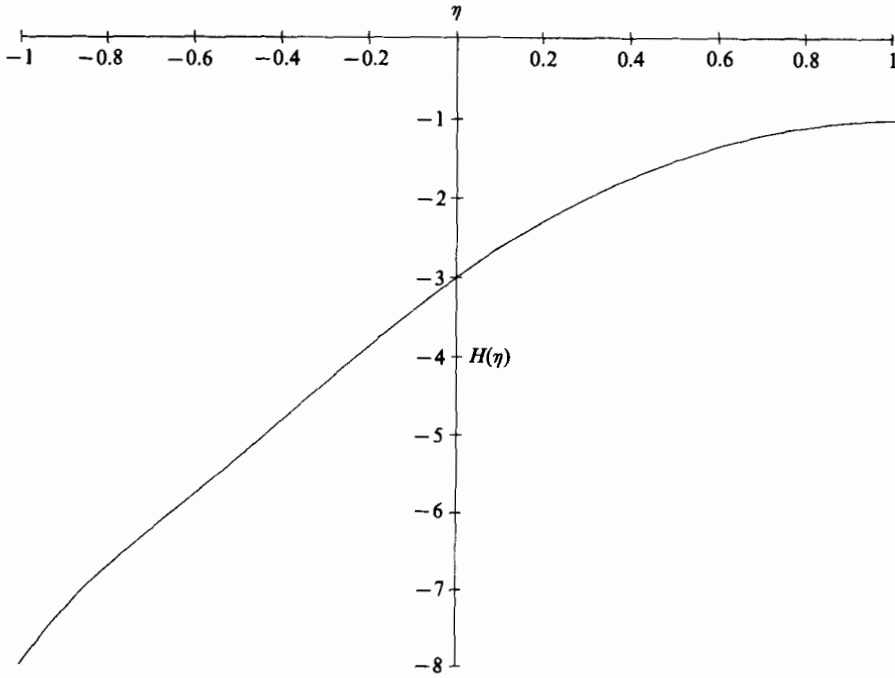

FIGURE 2. The function  $H(\eta)$  as defined by (6.6) plotted in the range  $-1 \leq \eta \leq 1$ , where  $\eta^2 = k_1/k_2$ .

Then we find for case (i)

$$\frac{\Delta c_2}{(\Delta c_2)_{S=0}} = \frac{1}{2}r \left\{ \frac{I(k_1, k_2) + rJ(k_1, k_2)}{K(k_1, k_2) - rL(k_1, k_2)} \right\} = F(k_1, k_2), \quad (6.11)$$

where  $(\Delta c_2)_{S=0}$  is the value of  $\Delta c_2$  in the relevant gravity – only case evaluated at the same frequency  $\sigma_2 = \sigma_2(S = 0)$ . For case (i) here this is given by (6.1). The functions  $I(k_1, k_2)$ ,  $J(k_1, k_2)$ ,  $K(k_1, k_2)$  and  $L(k_1, k_2)$  are given by

$$I(k_1, k_2) = 9k_2(k_1^2 - 2k_2^2) - 3k_1^2(4k_1 + k_2)(1 + R_1) - 8k_1k_2^2(1 + R_1)(1 + R_2), \quad (6.12)$$

$$J(k_1, k_2) = 27k_2^2(k_2^2 - k_1^2) + 18k_1(k_1^3 + k_2^3)(1 + R_1) + 32k_1^3k_2(1 + R_1)^2(1 + R_2) + 60k_1k_2^3(1 + R_1)(1 + R_2), \quad (6.13)$$

$$K(k_1, k_2) = k_1^2(1 + R_1) + 3k_2^2, \quad (6.14)$$

$$L(k_1, k_2) = 9k_2(k_2^2 - k_1^2) + 6k_1^2(k_1 + k_2)(1 + R_1) + 4k_1k_2^2(1 + R_1)(1 + R_2). \quad (6.15)$$

For case (ii), the result by symmetry, is

$$\frac{\Delta c_2}{(\Delta c_2)_{S=0}} = F(k_2, k_1), \quad (6.16)$$

where  $(\Delta c_2)_{S=0}$  is now given in (6.2).

For antiparallel propagation we find for case (iii) that

$$\frac{\Delta c_2}{(\Delta c_2)_{S=0}} = \frac{1}{2}r \left\{ \frac{-I(k_1, k_2) + rJ(k_1, k_2)}{K(k_1, k_2) + rL(k_1, k_2)} \right\} = G(k_1, k_2), \quad (6.17)$$

where  $(\Delta c_2)_{S=0}$  is given in (6.3) and for case (iv), by symmetry,

$$\frac{\Delta c_2}{(\Delta c_2)_{S=0}} = G(k_2, k_1), \quad (6.18)$$

where  $(\Delta c_2)_{S=0}$  is given in (6.4).

Finally in this section we point out that it is not always possible to obtain a finite value for  $\Delta c_2/(\Delta c_2)_{S=0}$  because of triad interactions. Specifically this is because either the coefficients  $A$  and  $C$  or  $B$  and  $D$  are infinite when

$$\sigma_1 \pm \sigma_2 = \sigma_3, \quad (6.19)$$

$$\mathbf{k}_1 \pm \mathbf{k}_2 = \mathbf{k}_3, \quad (6.20)$$

where

$$\sigma_i^2 = g|k_i| + S|k_i|^3 \quad (i = 1, 2, 3). \quad (6.21)$$

Similar singularities occur at these wavenumbers in the second-order part of  $T(\mathbf{k}, \mathbf{k}_1, \mathbf{k}_2, \mathbf{k}_3)$ .

Equations (6.19)–(6.21) were first shown to possess non-trivial solutions by McGoldrick (1965). Energy is continually transferred between the modes and so no steady solutions exist in general at those values of the resonant wavenumbers. When  $S = 0$ , no triad solutions are possible and so  $A, B, C, D$  and also  $T(\mathbf{k}, \mathbf{k}_1, \mathbf{k}_2, \mathbf{k}_3)$  are always non-singular. Hence the results in §6.1 are always well behaved as is the general result when  $S = 0$  for arbitrary angle  $\theta$  between wavevectors  $\mathbf{k}_1$  and  $\mathbf{k}_2$ . When  $g = 0$ , triad solutions are possible but not for parallel propagation. Thus our results in §6.2 are non-singular but the general expression for  $(\Delta c_2)_{g=0}/(\Delta c_2)_{S=0}$  is singular for some values of  $\theta$  (McGoldrick 1965, figures 2 and 3). The general expressions in §6.3 will always be singular for any value of  $\theta < \frac{1}{2}\pi$  (McGoldrick, figure 1) for certain values of  $k_1$  and  $k_2$ .

This situation is unavoidable and limits the application of our results.

The results of this sub-section will find direct applicability to the general problem of instabilities of nonlinear gravity–capillary waves.

## 7. Results and discussion

### 7.1. Results

The analytic formulae of the previous section are now supplemented by numerical results for realistic cases with arbitrary angle of intersection  $\theta$  to guide our understanding.

We construct the quantity  $\tilde{T}_{1,2}$  given by

$$\tilde{T}_{1,2} = \frac{4\pi^2 T_{1,2}}{k_1 k_2^2} = \frac{\delta}{\sigma_1 a_1^2 a_2 k_2^2} = \frac{\Delta c_2}{a_1^2 k_2 \sigma_1} = \frac{\Delta c_1}{a_2^2 k_2 \sigma_2}. \quad (7.1)$$

This is a dimensionless function of the three parameters  $\nu = k_2/k_1$ ,  $\cos \theta = (\mathbf{k}_1 \cdot \mathbf{k}_2)/k_1 k_2$  and  $K$ , where  $0 < \nu \leq 1$  and  $0 \leq \theta \leq \pi$ . We present our results in the form of polar diagrams showing lines of equal  $\tilde{T}_{1,2}$  for four wavelengths  $\lambda_1 = 200$  cm, 5 cm, 1 cm and 0.1 cm. We take the two wavenumber vectors to be

$$\mathbf{k}_1 = k_1(1, 0), \quad \mathbf{k}_2 = k_1(X, Y) \quad (7.2)$$

and we set  $S = 74 \text{ cm}^3/\text{s}^2$ .

The result for  $\lambda_1 = 200$  cm is shown in figure 3(a, b). Figure 3(a) covers the range

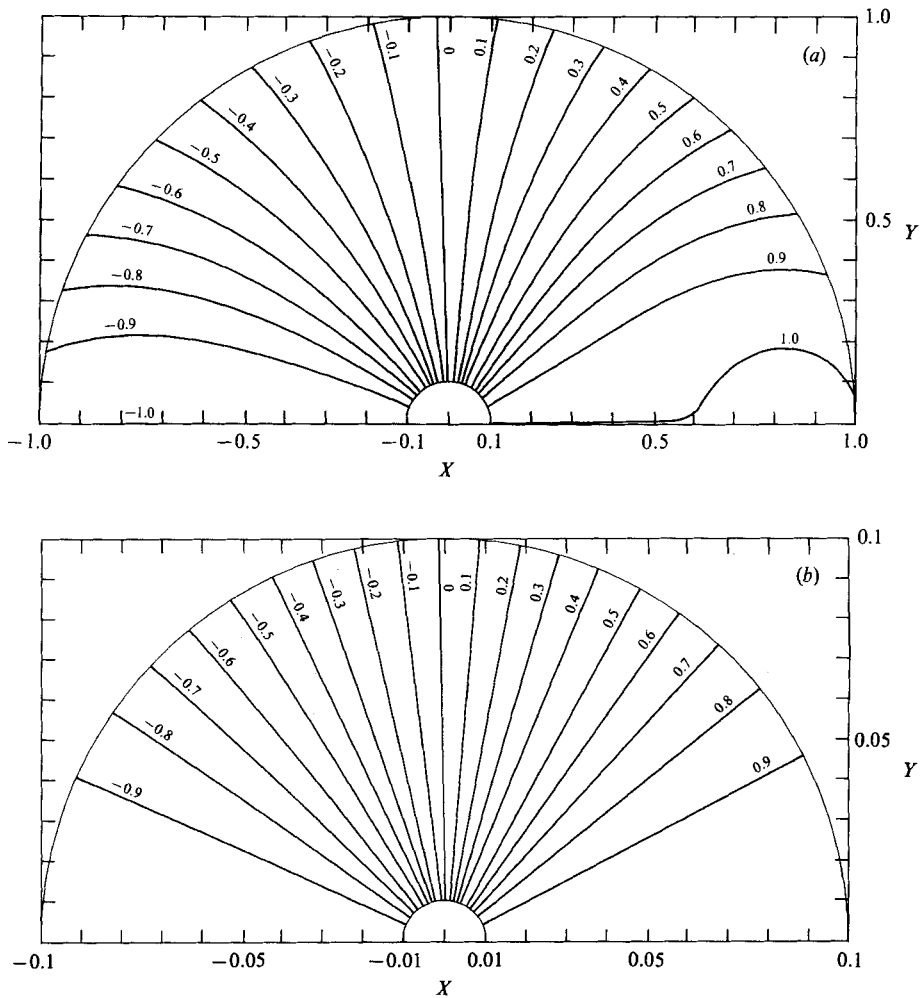

FIGURE 3. Lines of constant  $\tilde{T}_{1,2}$  as defined in equation (7.1) for  $\lambda_1 = 200$  cm in the ranges: (a)  $0.1k_1 \leq k_2 \leq k_1$ ; (b)  $0.01k_1 \leq k_2 \leq 0.1k_1$ , where  $k_1 = k_1(1, 0)$  and  $k_2 = k_1(X, Y)$ .

$0.1k_1 \leq k_2 \leq k_1$ , and figure 3(b) covers  $0.01k_1 \leq k_2 \leq 0.1k_1$ . The same arrangement holds in all other following figures. Since  $\lambda_1 = 200$  cm is essentially a gravity wave and since  $\lambda_2 > \lambda_1$  these two diagrams summarize the results for ‘pure’ gravity waves. Figure 4(a, b) for  $\lambda_1 = 5$  cm (and again with  $\lambda_2 > \lambda_1$ ) is for cases dominated by gravity, but somewhat influenced by surface tension. The lines of constant  $\tilde{T}_{1,2}$  are rotated more to the left than in figure 3(a, b). This implies an increase in  $\Delta c_i$  when  $\theta = 0$  and a decrease when  $\theta = \pi$ . The case  $\lambda_1 = 1$  cm, shown in figure 5(a, b), is typical for situations where gravity and surface tension have a comparable role. Here the picture is considerably different from the previous figures. The shaded area for  $X, Y \geq 0$  represents the area where significant triad interaction takes place. This area is located around the triad resonance curves and is characterized by large values and gradients of  $\tilde{T}_{1,2}$ . In this area our quartet interaction solutions are not applicable, as was mentioned in §6. We note the fact that even some cases of parallel propagation are resonant, whereas every case in the left-hand side of figure 5(a, b) is non-resonant. The final case in this series is for a ‘pure’ capillary wave,  $\lambda_1 = 0.1$  cm, in the presence

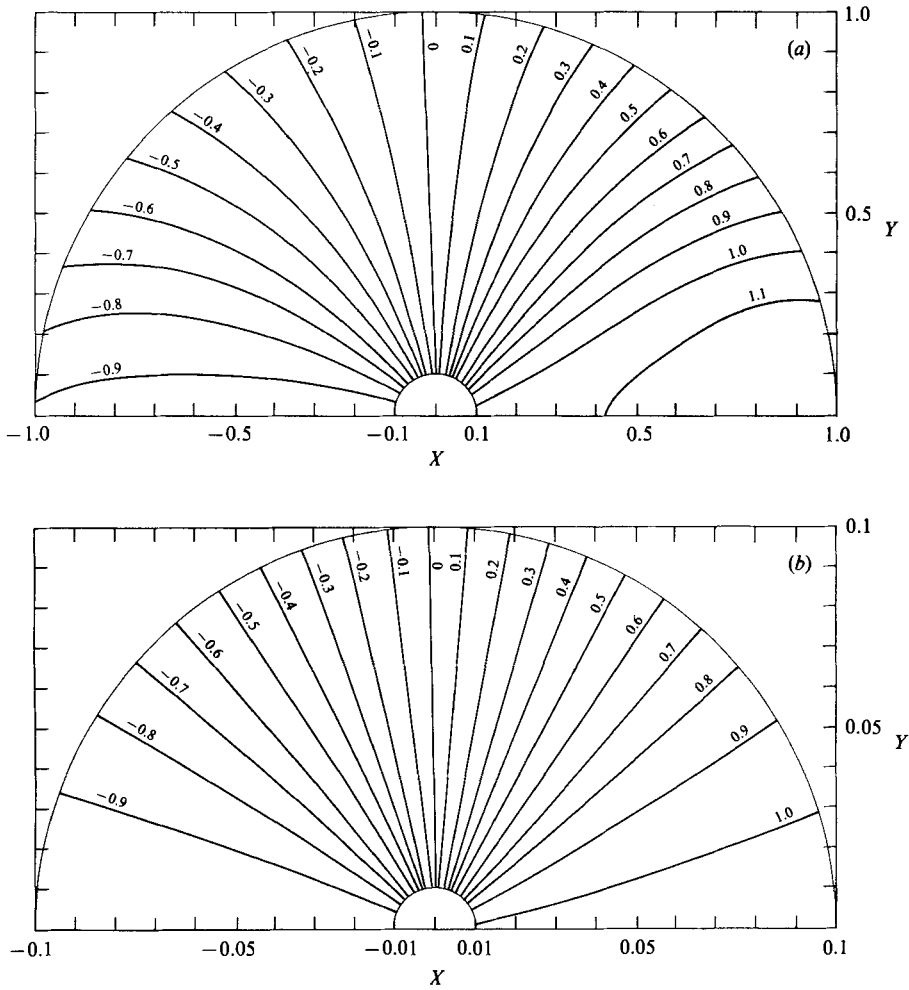

FIGURE 4. As in figure 3 but for  $\lambda_1 = 5$  cm.

of another wave. This other wave is in the capillary to gravity-capillary range,  $\lambda_2 = 0.1-1$  cm in figure 6(a) to  $\lambda_2 = 1-10$  cm in figure 6(b).

Now the triad interaction area has moved off the parallel axis, in keeping with the fact that pure capillary waves resonate in non-parallel triads (McGoldrick 1965). In fact  $\Delta c_i < 0$  is the case, for almost all non-resonant values of  $\theta$ , in keeping with the results of §2.

7.2. Discussion

The change in the phase speed of one wavetrain due to the presence of the other, divided by its own linearized speed is given by

$$\frac{\Delta c_1}{(\sigma_1/k_1)} = \tilde{T}_{1,2} \frac{\sigma_2}{\sigma_1} \frac{k_1}{k_2} (k_2 a_2)^2, \tag{7.3}$$

$$\frac{\Delta c_2}{(\sigma_2/k_2)} = \tilde{T}_{1,2} \frac{\sigma_1}{\sigma_2} \left(\frac{k_2}{k_1}\right)^2 (k_1 a_1)^2. \tag{7.4}$$

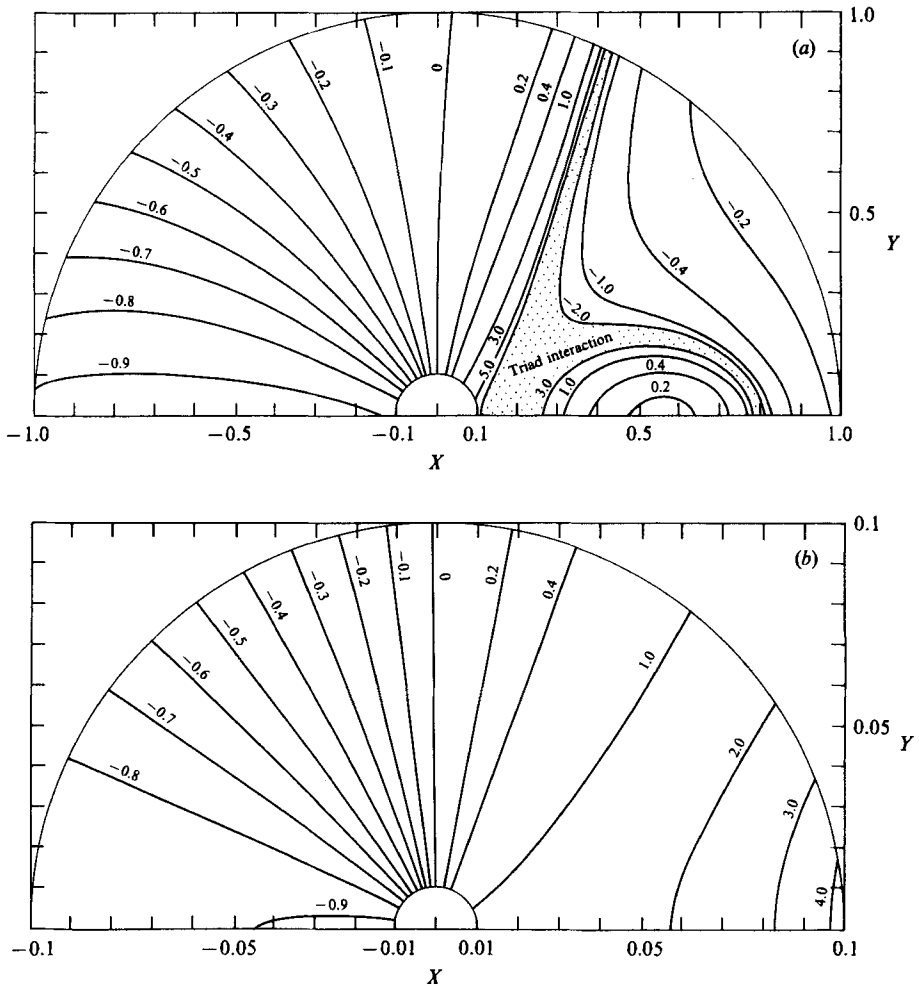

FIGURE 5. As in figure 3 but for  $\lambda_1 = 1$  cm.

In the sequel we focus on the effect the longer wave (no. 2) has on the shorter one (no. 1), which is more profound than the other way round. Substituting (6.21) into (7.3) yields

$$\frac{\Delta c_1}{(\sigma_1/k_1)} = \tilde{T}_{1,2} \left(\frac{k_1}{k_2}\right)^{\frac{1}{2}} \left(\frac{1+K(k_2/k_1)^2}{1+K}\right)^{\frac{1}{2}} (k_2 a_2)^2. \tag{7.5}$$

From figures 3–6 we see that the order of magnitude of  $\tilde{T}_{1,2}$  is unity. Assuming that  $(k_2 a_2)^2$  is limited by say 0.1,  $\Delta c_1/(\sigma_1/k_1)$  has an upper bound of the order of  $0.1\mu$  where

$$\mu = \left(\frac{k_1}{k_2} \frac{1+K(k_2/k_1)^2}{1+K}\right)^{\frac{1}{2}}. \tag{7.6}$$

Some values of  $\mu$ , which depends on two parameters  $K$  and  $(k_1/k_2)$  are given in table 2.

Thus one can see that for  $k_1/k_2 = 100$ ,  $\Delta c_1/(\sigma_1/k_1)$  can be as large as 1. Note that taking  $k_1/k_2 = 100$  means that we assume the existence of a uniform wavetrain (no. 1) which is several hundred wavelengths long. The realization of such circumstances

$k_1/k_2$	$\lambda_1(\text{cm})\dots$	200	5	1	0.1
10		3.16	2.99	2.00	0.36
100		10	9.45	5.00	0.59

TABLE 2. Numerical values of  $\mu$ , equation (7.6)

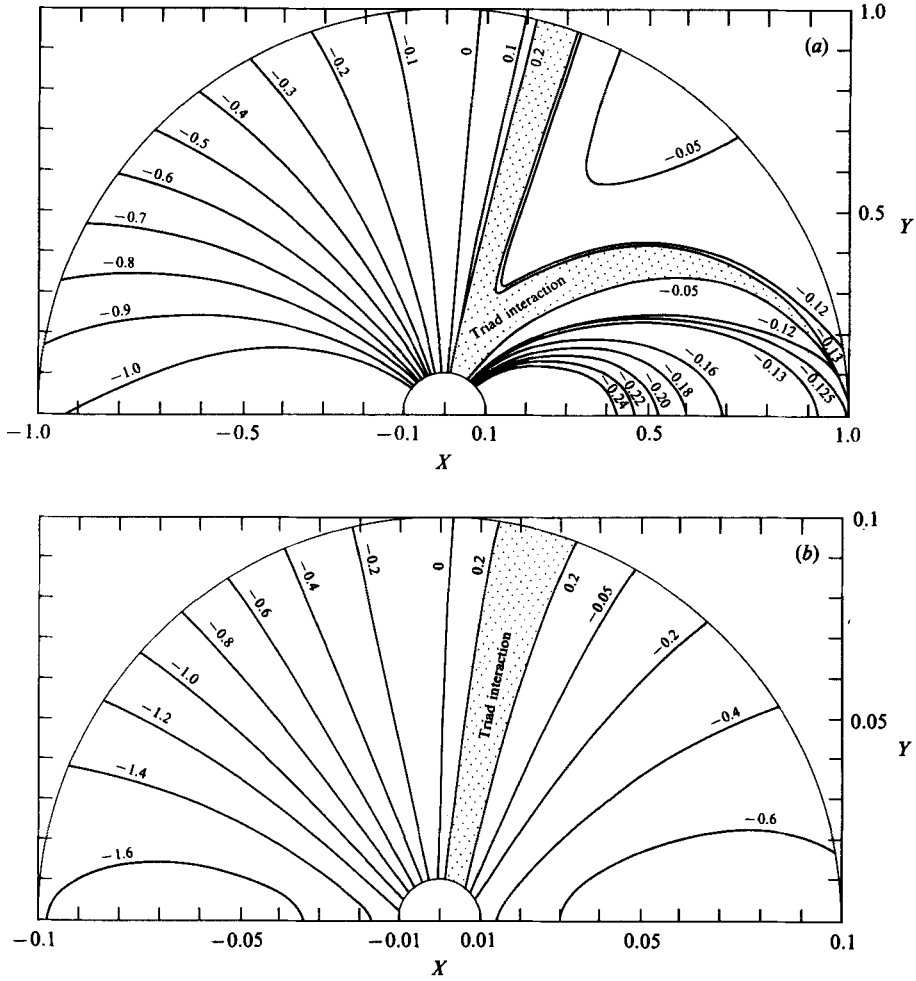

FIGURE 6. As in figure 3 but for  $\lambda_1 = 0.1$  cm.

is doubtful since strong modulations will probably enter and change the picture substantially.

### 7.3. Application

We conclude this section with a practical example, namely the two-dimensional scattering of gravity waves, as occurs when a two-dimensional obstacle is placed in a wave flume. For this case it is usually assumed that the reflected wave has the same frequency as that of the incident wave. Thus  $\Omega_1 = \Omega_2$  (see (2.10), (2.11)), and one can show that the reflected wavenumber  $\mathbf{k}^{(R)}$  is related to the incident wavenumber  $\mathbf{k}^{(I)}$  through

$$\mathbf{k}^{(R)} \approx -[1 + 3(k^{(I)} a^{(I)})^2 (1 - R_c^2)] \mathbf{k}^{(I)}, \quad (7.7)$$

where  $R_c$  is the reflection coefficient defined by the ratio of the reflected wave amplitude  $a^{(R)}$  to incident wave amplitude  $a^{(I)}$ . From (7.7) we see that the length of the reflected wave can be significantly shorter than that of the incident wave, excluding the case of total reflection.

We can generalize (7.7) to include capillarity. In fact

$$\mathbf{k}^{(R)} \approx - \left\{ 1 + \frac{[24 + 63K - 54K^2 - 120K^3]}{8(1+3K)(1+4K)(1-2K)} (k^{(I)} a^{(I)})^2 (1 - R_c^2) \right\} \mathbf{k}^{(I)}, \quad (7.8)$$

where now  $K = Sk^{(I)2}/g$ . The singularity at  $K = \frac{1}{2}$  corresponds to subharmonic resonance, a special case of triad interaction that we have already excluded from our analysis. When  $K = 0$ , that is for gravity waves, we recover (7.7). For  $0.5 < K < 0.702529$ ,  $|\mathbf{k}^{(R)}| < |\mathbf{k}^{(I)}|$  and hence the reflected wave can be longer than the incident wave, with equality at  $K = 0.702529$ . For capillary waves, we take  $K$  infinite and find

$$\mathbf{k}^{(R)} \approx - [1 + \frac{5}{8}(k^{(I)} a^{(I)})^2 (1 - R_c^2)] \mathbf{k}^{(I)}. \quad (7.9)$$

## 8. Summary

We have shown that the Zakharov (1968) kernel function  $T(\mathbf{k}, \mathbf{k}_1, \mathbf{k}_2, \mathbf{k}_3)$  can be used to calculate the change in phase speed of one train of water waves in the presence of another.

For gravity-capillary waves, we have derived the correct form of  $T(\mathbf{k}, \mathbf{k}_1, \mathbf{k}_2, \mathbf{k}_3)$ . The subsequent expression for  $\Delta c_2$  has been checked against that resulting from a derivation based on the method of Longuet-Higgins & Phillips (1962). The agreement that is found gives confidence in the accuracy of both derivations.

In general our results show that surface-tension effects of sufficient size change the sign as well as the magnitudes of  $\Delta c_1$  and  $\Delta c_2$ , away from conditions of triad resonance. Some of these changes are significant enough to be measured experimentally.

S.J.H. is CEEGB Research Fellow in Applied Mathematics at St. Catherine's College, Oxford. He completed part of this work as a Visiting Fellow in the School of Mathematics at the University of New South Wales. He is grateful to the Head and staff of the School for their hospitality.

Some part of this work are based on the M.Sc. thesis of I.G. submitted to the Technion, Israel Institute of Technology.

M.S. is grateful to Professor D. H. Peregrine and the staff of the School of Mathematics, University of Bristol, for their hospitality.

## Appendix

We present here for the first time the correct form of the Zakharov kernel function  $T(\mathbf{k}_0, \mathbf{k}_1, \mathbf{k}_2, \mathbf{k}_3)$  for gravity-capillary waves. Using the simplified notation of Crawford *et al.* (1981), we write

$$\begin{aligned} T(\mathbf{k}_0, \mathbf{k}_1, \mathbf{k}_2, \mathbf{k}_3) &= T_{0,1,2,3}. \\ \text{Then} \\ T_{0,1,2,3} &= - \frac{2V_{3,3-1,1}^{(-)} V_{0,2,0-2}^{(-)}}{\sigma_{1-3} - \sigma_3 + \sigma_1} - \frac{2V_{2,0,2-0}^{(-)} V_{1,1-3,3}^{(-)}}{\sigma_{1-3} - \sigma_1 + \sigma_3} - \frac{2V_{2,2-1,1}^{(-)} V_{0,3,0-3}^{(-)}}{\sigma_{1-2} - \sigma_2 + \sigma_1} \\ &\quad - \frac{2V_{3,0,3-0}^{(-)} V_{1,1-2,2}^{(-)}}{\sigma_{1-2} - \sigma_1 + \sigma_2} - \frac{2V_{0+1,0,1}^{(-)} V_{2+3,2,3}^{(-)}}{\sigma_{2+3} - \sigma_2 - \sigma_3} - \frac{2V_{-2-3,2,3}^{(+)} V_{0,1,-0-1}^{(+)}}{\sigma_{2+3} + \sigma_2 + \sigma_3} + W'_{0,1,2,3}. \end{aligned}$$



The second-order interaction coefficients are defined as

$$V_{0,1,2}^{(\pm)} = \frac{1}{8\pi\sqrt{2}} \left\{ [\mathbf{k}_0 \cdot \mathbf{k}_1 \pm k_0 k_1] \left[ \frac{\sigma_0 \sigma_1}{\sigma_2} \frac{k_2}{k_0 k_1} \right]^{\frac{1}{2}} + [\mathbf{k}_0 \cdot \mathbf{k}_2 \pm k_0 k_2] \left[ \frac{\sigma_0 \sigma_2}{\sigma_1} \frac{k_1}{k_0 k_2} \right]^{\frac{1}{2}} + [\mathbf{k}_1 \cdot \mathbf{k}_2 + k_1 k_2] \left[ \frac{\sigma_1 \sigma_2}{\sigma_0} \frac{k_0}{k_1 k_2} \right]^{\frac{1}{2}} \right\},$$

where  $k_i = |\mathbf{k}_i|$  and  $\sigma_i = \sigma(k_i)$  given by the linear dispersion equation (4.1). The third-order interaction coefficient

$$W'_{0,1,2,3} = W'(\mathbf{k}_0, \mathbf{k}_1, \mathbf{k}_2, \mathbf{k}_3)$$

is defined as

$$W'_{0,1,2,3} = W_{0,1,2,3} - \frac{S}{32\pi^2} \frac{(k_0 k_1 k_2 k_3)^{\frac{1}{2}}}{(\sigma_0 \sigma_1 \sigma_2 \sigma_3)^{\frac{1}{2}}} \times [(\mathbf{k}_0 \cdot \mathbf{k}_1)(\mathbf{k}_2 \cdot \mathbf{k}_3) + (\mathbf{k}_0 \cdot \mathbf{k}_2)(\mathbf{k}_1 \cdot \mathbf{k}_3) + (\mathbf{k}_0 \cdot \mathbf{k}_3)(\mathbf{k}_1 \cdot \mathbf{k}_2)],$$

where

$$W_{0,1,2,3} = \bar{W}_{-0,-1,2,3} + \bar{W}_{2,3,-0,-1} - \bar{W}_{2,-1,-0,3} - \bar{W}_{-0,2,-1,3} - \bar{W}_{-0,3,2,-1} - \bar{W}_{3,-1,2,-0},$$

with

$$\bar{W}_{0,1,2,3} = \frac{1}{64\pi^2} \left[ \frac{\sigma_0 \sigma_1}{\sigma_2 \sigma_3} k_0 k_1 k_2 k_3 \right]^{\frac{1}{2}} \{2(k_0 + k_1) - k_{1+3} - k_{1+2} - k_{0+3} - k_{0+2}\}$$

and

$$k_{i\pm j} = |\mathbf{k}_i \pm \mathbf{k}_j|, \quad \sigma_{i\pm j} = \sigma(k_{i\pm j}).$$

#### REFERENCES

- CLEAVER, R. P. 1980 Instabilities of surface gravity waves. Ph.D. thesis, University of Cambridge.
- CRAWFORD, D. R., LAKE, B. M., SAFFMAN, P. G. & YUEN, H. C. 1981 Stability of weakly nonlinear deep water waves in two and three dimensions. *J. Fluid Mech.* **105**, 177–191.
- HOGAN, S. J. 1985 The fourth order evolution equation for deep-water gravity–capillary waves. *Proc. R. Soc. Lond. A* **402**, 359–372.
- HOGAN, S. J. 1986 The potential form of the fourth-order evolution equation for deep-water gravity–capillary waves. *Phys. Fluids* **29**, 3479–3480.
- HOGAN, S. J. 1988 The superharmonic normal mode instabilities of nonlinear deep-water capillary waves. *J. Fluid Mech.* **190**, 165–177.
- HOLLIDAY, D. 1977 On nonlinear interactions in a spectrum of inviscid gravity–capillary surface waves. *J. Fluid Mech.* **83**, 737–749.
- LONGUET-HIGGINS, M. S. 1962 Resonant interactions between two trains of gravity waves. *J. Fluid Mech.* **12**, 321–332.
- LONGUET-HIGGINS, M. S. & PHILLIPS, O. M. 1962 Phase velocity effects in tertiary wave interactions. *J. Fluid Mech.* **12**, 333–336.
- MCGOLDRICK, L. F. 1965 Resonant interactions among capillary–gravity waves. *J. Fluid Mech.* **21**, 305–331.
- PHILLIPS, O. M. 1977 *The Dynamics of the Upper Ocean*, 2nd edn. Cambridge University Press.
- STIASSNIE, M. & SHEMER, L. 1984 On modification of the Zakharov equation for surface gravity waves. *J. Fluid Mech.* **143**, 47–67.
- STOKES, G. G. 1847 On the theory of oscillatory waves. *Trans. Camb. Phil. Soc.* **8**, 441–455.
- WEHAUSEN, J. V. & LAITONE, E. V. 1960 Surface waves. *Encyclopedia of Physics* (ed. S. Flugge), vol. 9, pp. 446–757. Springer.
- WILLEBRAND, J. 1975 Energy transport in a nonlinear and inhomogeneous random gravity wave field. *J. Fluid Mech.* **70**, 113–126.

- YUEN, H. C. & LAKE, B. M. 1982 Nonlinear dynamics of deep-water gravity waves. *Adv. Appl. Mech.* **22**, 67–229.
- ZAKHAROV, V. E. 1968 Stability of periodic waves of finite amplitude on the surface of a deep fluid. *J. Appl. Mech. Tech. Phys.* **2**, 190–194.